

LÜDECKE

Since 1930. The perfect connection.



Quality Made in Germany





KLE

- 4** Company
- 6** Product Range
- 10** Milestones
- 12** Sustainability
- 14** Manufacturing
- 16** Logistics
- 18** Engineering
- 20** Service
- 22** Training Area

COMPANY

For more than 90 years, **LUDECKE** has been your competent partner for coupling systems used to connect flexible media-carrying lines to tools, machinery and equipment.

Since 1949, we have been producing fittings for a wide variety of applications and media at our site in Amberg. Our products are sold worldwide via specialist, technical dealers or are utilised as original equipment by leading machine builders (OEM). We develop and produce sophisticated, innovative and sustainable products according to the highest quality standards. The portfolio comprises a comprehensive standard range as well as individually designed custom-made items.

With our broad product portfolio, long-time experience and diverse range of services, we always guarantee safe and efficient solutions for your daily work.



Engineered and Made in Germany - **LUDECKE** has kept this promise since 1930.

The perfect connection



PRODUCT RANGE

We offer a broad range of high-quality products for various applications and media - made of selected materials, tailored to individual needs.

PNEUMATICS



Energy-efficient quick connect couplings equipped with various safety mechanisms for compressed air applications.

TEMPERATURE REGULATION



Quick connect coupling systems for temperature regulation in the plastic processing industry (injection moulding or pressure die-casting).

CONSTRUCTION INDUSTRY



Robust, tried and tested coupling systems for outdoor applications in the construction industries.

The most comprehensive range of coupling systems and accessories

PROCESSING INDUSTRY



Couplings and fittings for applications requiring specific hygiene standards or for conveying aggressive media.

WATER APPLICATION



Coupling systems and wand nozzles for water supply for professional or private use.

ACCESSORIES



Supplementary solutions for every product range.

At a glance: www.luedecke.de/en/products





You will find the **LUDECKE** product range in a variety of applications and industries:

- Fluid Technology
- Industry, Machine and Plant Construction
- Drive Technology
- Petrochemical Industry
- Transport and Traffic
- Plastics Technology
- Construction Industry, Municipal Technology
- Chemical Technology, Pharmaceutical and Medical Engineering
- Agriculture, Gardening and Landscaping
- Server and Processor Cooling
- Welding Technology
- Food Industry
- Snowmaking Technology
- Craftsmanship

MILESTONES

In 1930, engineer Emil Georg Lüdecke developed the claw coupling system for compressed air used worldwide today. This development paved the way for the successful story of **LÜDECKE** GmbH.

Today, we manufacture around 30,000 products and are the expert company for all types of coupling systems in the low-pressure range.



Emil Georg Lüdecke
Founder
(1930 - 1973)



Erwin Bogner
Chief Executive Officer - CEO
(1956 - 2015)



Klaus Herdegen
Chief Executive Officer - CEO
(since 2000)



Andreas Sperl
Chief Executive Officer - CEO
(since 2019)/ Sales Director



Michael Bogner
Chief Executive Officer - CEO
(since 2024)/ Purchasing Director

- 1930:** E. Georg **LUDECKE** KG is founded in Leipzig by Emil Georg Lüdecke
- 1949:** After destruction, new start in Amberg
- 1969:** Construction of a new factory in Amberg
- 1999:** Initial operation of a new fully automatic high rack warehouse
- 2007:** New construction of the administration building including an additional production hall
- 2013:** Extension of the fully automatic high rack warehouse
- 2015:** Start of company extension (production halls, seminar area)
- 2016:** Initial operation of the new production halls
- 2017:** Initial operation of the **LUDECKE ACADEMY**
- 2023:** Start of the **LUDECKE** energy campus

Technical Drawing
of a claw coupling from the year 1938

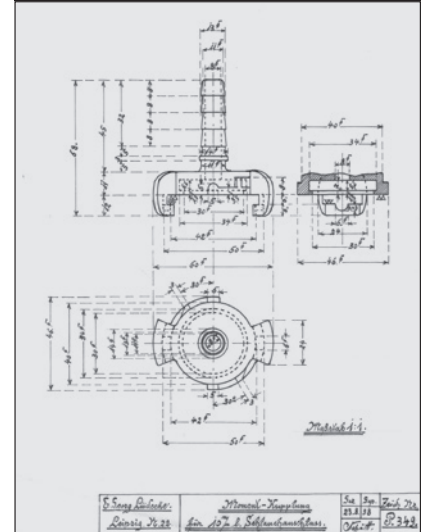

Continuity in innovation through progression and flexibility

SUSTAINABILITY

We made it our key mission to take on responsibility and to act sustainably in all our activities.

This is why we provide our customers with high-quality and long-lasting products while at the same time acting responsibly with regard to employees, partners, the environment and society.

To be able to act sustainably and economically successful at the same time, it is important to transfer this responsibility to all areas of the company. This starts with the selection of materials and suppliers and ranges from development and manufacturing to sales and logistics as well as to numerous other activities.

With the **LUDECKE** energy campus we guarantee an ecological and future-oriented energy supply for our Amberg site.

It is our goal to gradually become more and more efficient and to create added value for all parties involved.



Our goals are convincing: In 2015 we were certified for our environmental management (ISO 14001:2015).



A shared responsibility

MANUFACTURING

Our employees use the most advanced machine technology and therefore ensure highest quality and efficiency. Starting from construction and engineering to the automatic and digitalized production to quality assurance - we guarantee a maximum of innovation, safety and customer service at all times.

Our production has a broad spectrum of high-performance machinery and equipment according to the latest, up-to-date technology. Consistent supply chain management from receiving raw materials to delivering our products ensures a controlled and optimized flow of manufacturing and material.

Through the complete in-house production of our products, we can respond quickly and flexibly to the most diverse customer requirements in order to deliver the best possible solutions. In addition to our core competences, we work together with high-performance, specialized partners in the fields of surface and sealing technology as well as heat treatment.



We meet highest requirements: Since 1994, the Quality Management of the **LUDECKE** GmbH has been certified according to ISO 9001:2015.



Since 1930 - Quality through Precision from Amberg

LOGISTICS

With our state-of-the-art production, distribution and storage technology, we guarantee our customers a reliable, fast and cost-effective product delivery offering more than 30,000 saleable products.

The fully automatic high-rack warehouse is directly integrated into the ERP system. Equipped with a customized shipping system, we offer immediate supply and transparent commissioning of the entire product range.

Agility, flexibility and continuous improvement are our principles.





Perfect service through agility and reliability worldwide

ENGINEERING

In cooperation with our sales and technology department, we develop sophisticated coupling systems. All departments, from engineering and production up to quality assurance, are connected via state-of-the-art software systems. This enables team oriented collaboration leading to fast, efficient and top-quality product development.

Our series are available in a wide variety of materials, sizes, valve types and technologies to ensure optimum functionality and ease of use, depending on the application. We aim at delivering excellent coupling systems which are functional, durable as well as environmentally friendly.

We also offer extensive product testing in our own test center. Ranging from pressure, to binding and temperature tests - our trained specialists perform specific application tests on a regular basis.



SERVICE

Purchasing **LUDECKE** products, is the greatest proof of trust from our customers. Maintaining this trust is our constant motivation: We want to be the preferred supplier of our world-wide customers.

This is why we support all sales partners with a first-class all-round service. This includes individual and qualified consulting, transparent project planning, targeted marketing support as well as customer-specific trainings. We aim at building a perfect team with our customers and at achieving best results at all times.





For **LUDECKE** it is very important to equip their sales partners and users with a comprehensive product knowledge.

In tailored trainings, our sales and technical experts demonstrate how the products are used for different applications.

A reliable partner at your side

TRAINING AREA

The spacious, light-flooded and air-conditioned training rooms of the **LÜDECKE ACADEMY** are equipped with the latest technology and can be used for all types of trainings, conferences or workshops.

The in-house gourmet canteen takes care of your physical well-being with fresh, healthy and varying dishes from the region.

A special highlight is the large rooftop terrace with numerous seating options offering a wonderful view over the city of Amberg and the **LÜDECKE** park.

In addition to our own events, you can also book the **LÜDECKE ACADEMY** for your events. Take advantage from our extensive experiences in catering and event management.





LÜDECKE

Since 1930. The perfect connection.

LÜDECKE GmbH · Heinrich-Hauck-Str. 2 · D-92224 Amberg · Telephone: +49 96 21 76 82 0
info@luedecke.de - www.luedecke.de